

SPECIFICATION OF SAW FILTER

YOKETAN CORP.

Spec no: SM3838F-04795-020-NJ-A

1. Type : SM3838 (Lead Free Parts)

2. Product Dimension

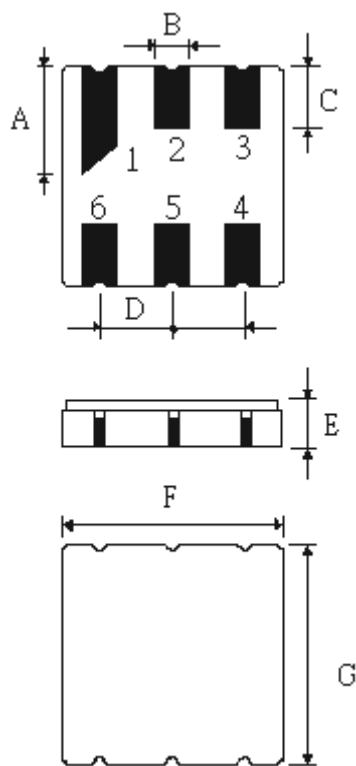

Pin	Connection
2	Input
5	Output
1, 3, 4, 6	Ground

Sign	Data (unit:mm)	Sign	Data(unit:mm)
A	1.90±0.1	E	1.35±0.15
B	0.64±0.1	F	3.80±0.15
C	1.00±0.1	G	3.80±0.15
D	1.27±0.1		

SPECIFICATION OF SAW FILTER

YOKETAN CORP.

3. Test Circuit

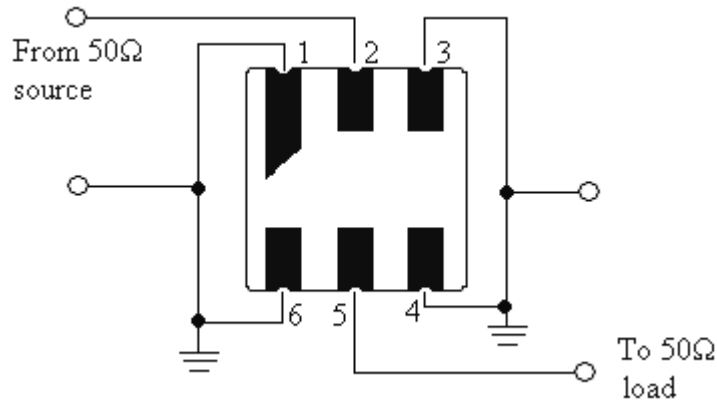

4. Performance

4-1. Maximum Ratings

Rating		Value
DC Voltage	V_{DC}	12 V
Input Power Level	P	10 dBm
Operation temperature	T_A	-10 to +65
Storage temperature	T_{stg}	-40 to +85

4-2. Electronic Characteristics

Item		Min	Typ.	Max	Unit
Center Frequency	f_c	--	479.5	--	MHz
3dB Bandwidth	$BW3$	--	20.0	--	MHz
Usable Bandwidth	BW	--	± 8.0	--	MHz
Insertion Loss	IL 471.50 MHz 487.50 MHz	--	3.5	4.5	dB
Absolute Attenuation	α $f_c - 100.0\text{MHz} \dots f_c - 50.0\text{ MHz}$	50	--	--	dB
	$f_c + 50.0\text{MHz} \dots 2.5x f_c$	55	--	--	dB
Passband Ripple	$\Delta \alpha$ 471.50 MHz 487.50 MHz	--	--	2.0	dB
Input / Output Impedance		50Ω			

5. Frequency Response

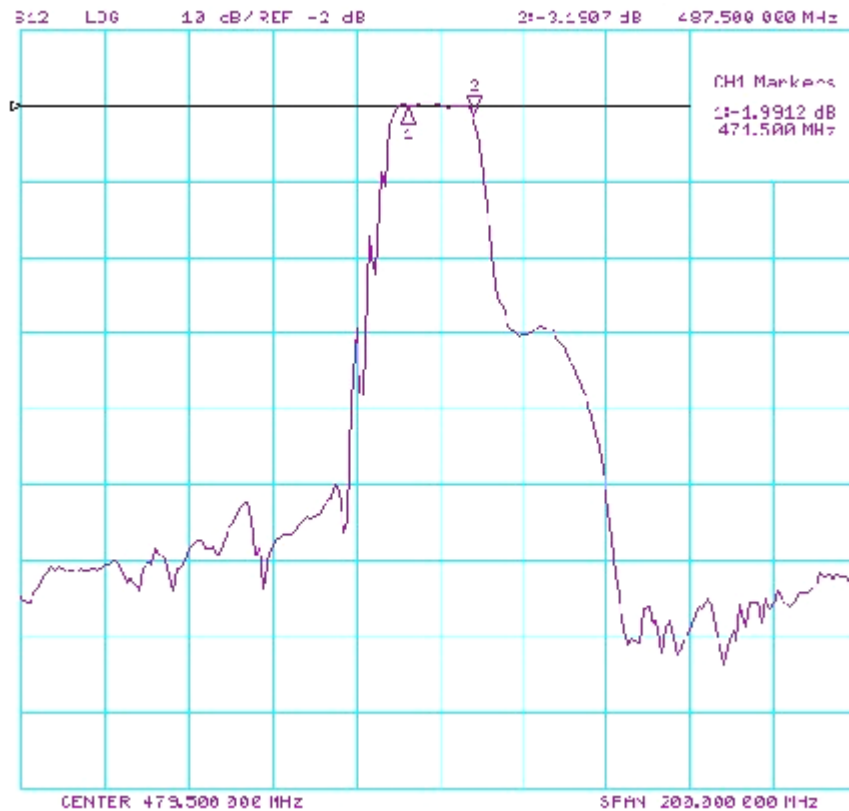

6. Notice

1. Unless noted otherwise, all measurements are made with the filter installed in the specified test fixture that is connected to a 50Ω test system with $VSWR \leq 1.2:1$. The test fixture L and C are adjusted for minimum insertion loss at the filter center frequency, f_c . Note that insertion loss, bandwidth, and passband shape are dependent on the impedance matching component values and quality.
2. Frequency aging is the change in f_c with time and is specified at +65°C or less. Aging may exceed the specification for prolonged temperatures above +65°C. Typically, aging is greatest the first year after manufacture, decreasing in subsequent years.
3. Turnover temperature, T_0 , is the temperature of maximum (or turnover) frequency, f_0 . The nominal frequency at any case temperature, T_C , may be calculated from:

$$f = f_0 [1 - FTC (T_0 - T_C)^2]$$
4. The specifications of this device are based on the test circuit shown above and subject to change or obsolescence without notice.